

"Idea Thief" Elon Musk Steals His Hyperloop From Another Inventor

Some technologies are not meant for public view or accreditation until the time is right. When these **amazing scientific advances** are brought forth it is done slowly and presented as cool and convenient. As with computers, cell phones and the internet among many other modern technologies. Always set in **boring terms** so the general public doesn't notice. One rule applies. **The military gets it first.** Then some **civilian corporation** with close ties and **funding** from the **U.S. government** just happens to "**pick up**" the research. Military research and development that is many years old has a second market in the public sector. This may be the case with **Deep Underground Base and Tunneling** technology that has been rumored to **exist for decades**. These documented subjects are dismissed as theory **until they are no longer theory**. Now the idea of **underground supersonic tunnel transit connecting cities** is publicized in the form of **Elon Musk's HyperLoop** concept. Being originally tested above ground. **SpaceX** is taking the idea subterranean.

Hyperloop Alpha

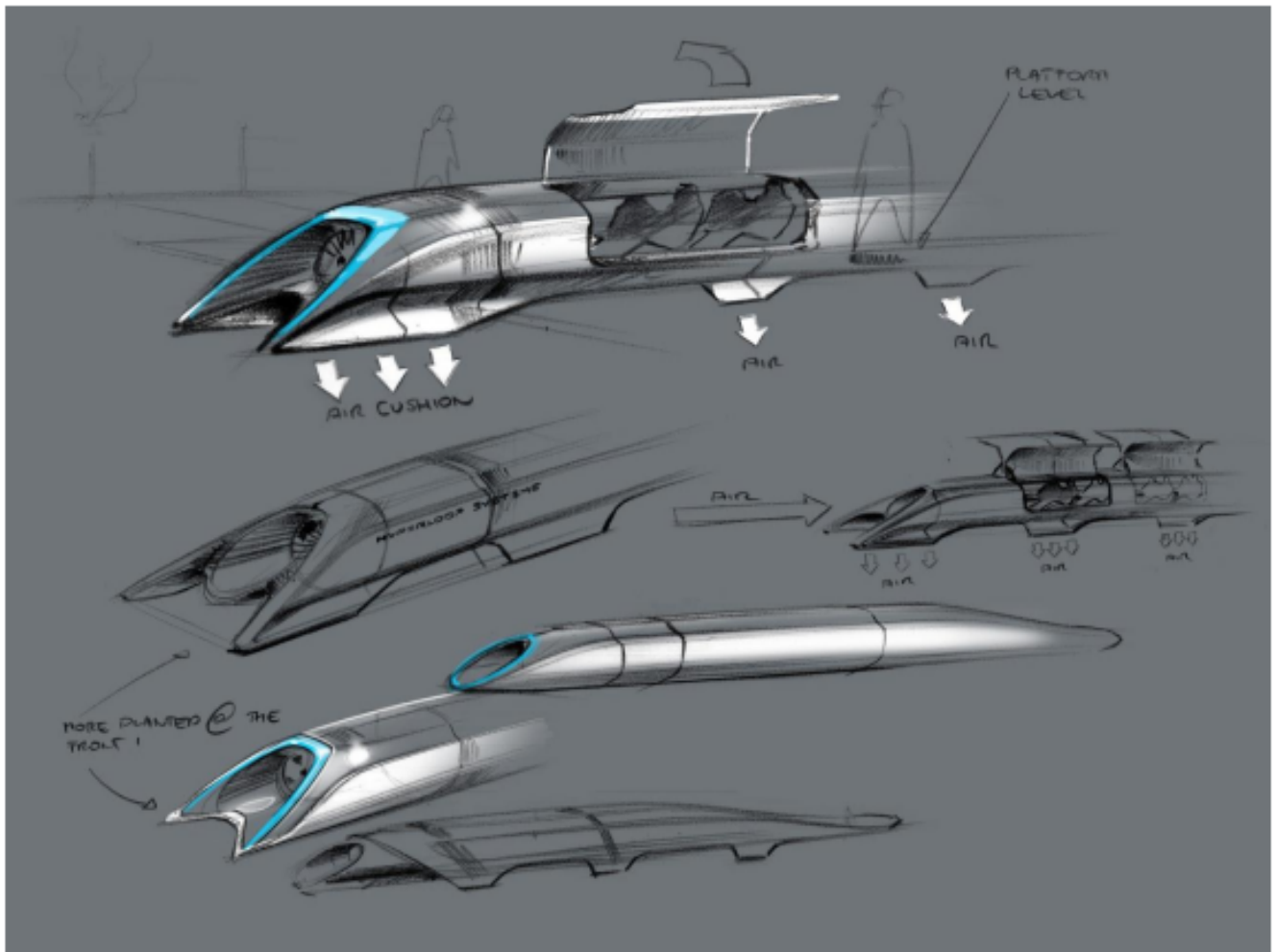

Such a **boring** endeavor being undertaken. It is true he is the only one in the world that can say something like that and actually mean it. Having somehow gotten the keys to the kingdom to many technologies that used to be the **sole domain of national governments** it would be hard to discount the statement. What is this technology **based on** and **what will it look like** in its **final version**? A **prototype** is **currently** being tested at **Space X Headquarters.Musk** himself leaving much room for speculation with nebulous **Tweets** about underground tunnels. **Possibly** even pitching it as an infrastructure project to the new U.S. Administration.

Apparently getting verbal approval from the administration to build a system from N.Y. to D.C. that could complete a trip in 29 minutes.



It has been speculated that this **very same system** has been functional for years. The **HyperLoop** and **V.H.S.T.** (**V**ery **H**igh **S**peed **T**ransit System) first proposed in **1972** are basically the same idea. **Almost identical in concept.** An **aerodynamic train** like **pod** configuration in a specially pressurized or **vacuum**

sealed tunnel gliding on **magnetic levitation** or a bed of **high speed air**. Overcoming air friction. Able to carry both passengers and cargo at **supersonic speeds**. **Crossing the entire U.S. in an hour.** Almost every science fiction fan has come across ideas of a supersonic transit system underground connecting major **Deep Underground Bases**.

Here it is. It couldn't **possibly** have **existed** before but now the **same exact design** is being tested in the form of the **HyperLoop**. Teams from around the world are competing for the best **civilian version** prototype in a **SpaceX** sponsored competition.

**TRANS-PLANETARY SUBWAY SYSTEMS
A BURGEONING CAPABILITY
R.M.Salter, Rand Corporation, Feb. 1978**

SOURCE: JOHN RHODES

**A SINGLE, TWO-WAY PLANETRAN
ELLIPTICAL, 28 FOOT DIAMETER
TUNNEL. THE TUBE-SHUTTLES
CAN CARRY 200-500 PASSENGERS.**

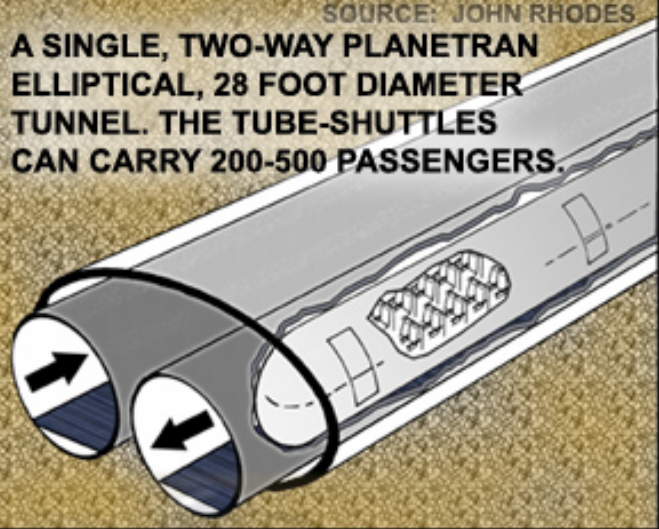

"Civil Defense shelter and underground industrial deployment plus Planetran/FRS transportation features will enhance U.S. Defense posture."

READ MORE ABOUT IT AT REPTOIDS.COM

Many designs have been put forth and all based on the work of **Robert M. Salter** a lead scientist with the **Rand Corporation** that wrote the **Very High Speed Transit System** about the **V.H.S.T.** in **1972**. Another followed in **1978** titled "**Trans Planetary Subway Systems: A Burgeoning Capability**". These

documents form the basis for theories that this technology already exists and has been in use for quite sometime by the government. **Salter** was interviewed in a **June 11 1972** **article by L.A. Times** science writer **George Getz** as reported by **Intellihub**. This along with the documents and **patents** filed around the same time fueled a lot of questions.

A Rand corporation physicist has devised a rapid transit system to get you from Los Angeles to NY in half an hour for a \$50 fair. He said existing technology made such a system feasible and so does a cost analysis. The essence of the idea is to dig a tunnel more or less along the present routes of U.S. highways 66 and

***thirty.** The tunnel would contain several large tubes for East West travel of trains that float on magnetic fields, moving at **top speeds of 10,000 mph.** Passengers would be faced forward during acceleration, backward during deceleration. **According to R. M. Salter Jr. head of the physical sciences department at Rand, the idea of high-speed train travel using electromagnetic suspension was first put forward in 1905 and actually patented in 1912.** The trains he suggested now would be single cars rather than actual trains, and would be big enough to carry both passengers and freight, including large containers and automobiles. LA Times June 11 1972*

This article has led many to speculate that **Deep Underground Bases and the Tunnel systems** that connect them have been in use for many years. Precious little hard proof has come up that this system actually exists in the capacity described here. Although some of this evidence is very compelling. The **SpaceX** concept is very similar to **Salter's design.**

***The tubes would be emptied of air, almost to the point of vacuum, so the trains would not need much power to overcome air resistance.** They would not even have to be streamlined. In addition to an electromagnetic roadbeds, the opposing electromagnetic loops of wires in the floors of the gondolas would be super cooled with liquid Helium to further eliminate electrical resistance. LA Times June 11 1972*

No doubt underground bases such as **N.O.R.A.D., Weather Mountain** and many others have been popularized and tunneling projects are going on all around the world. Some more intriguing than others. Still tantalizing connections come too light from time to time reinforcing the narrative that the **public is not being told the whole story.**

What may be more telling could be the **method of tunneling** that may be used if a larger version of **SpaceX's HyperLoop** were to be built. Many researchers have pointed to **advanced tunneling methods** and **boring equipment** possibly used by the **Defense Department**. **Boring machines** first **patented** by the **Atomic Energy Commission** and **US Energy**. These could be used to construct **Deep Underground Bases**. As depicted in the patents the boring machines **melt the surrounding rock** leaving a perfectly **smooth surface** behind. If such **boring machines** were built, they could make circular patterns at different levels connected by vertical corridors. Forming a multilevel turn key sealed **Underground** or even **Underwater** base.

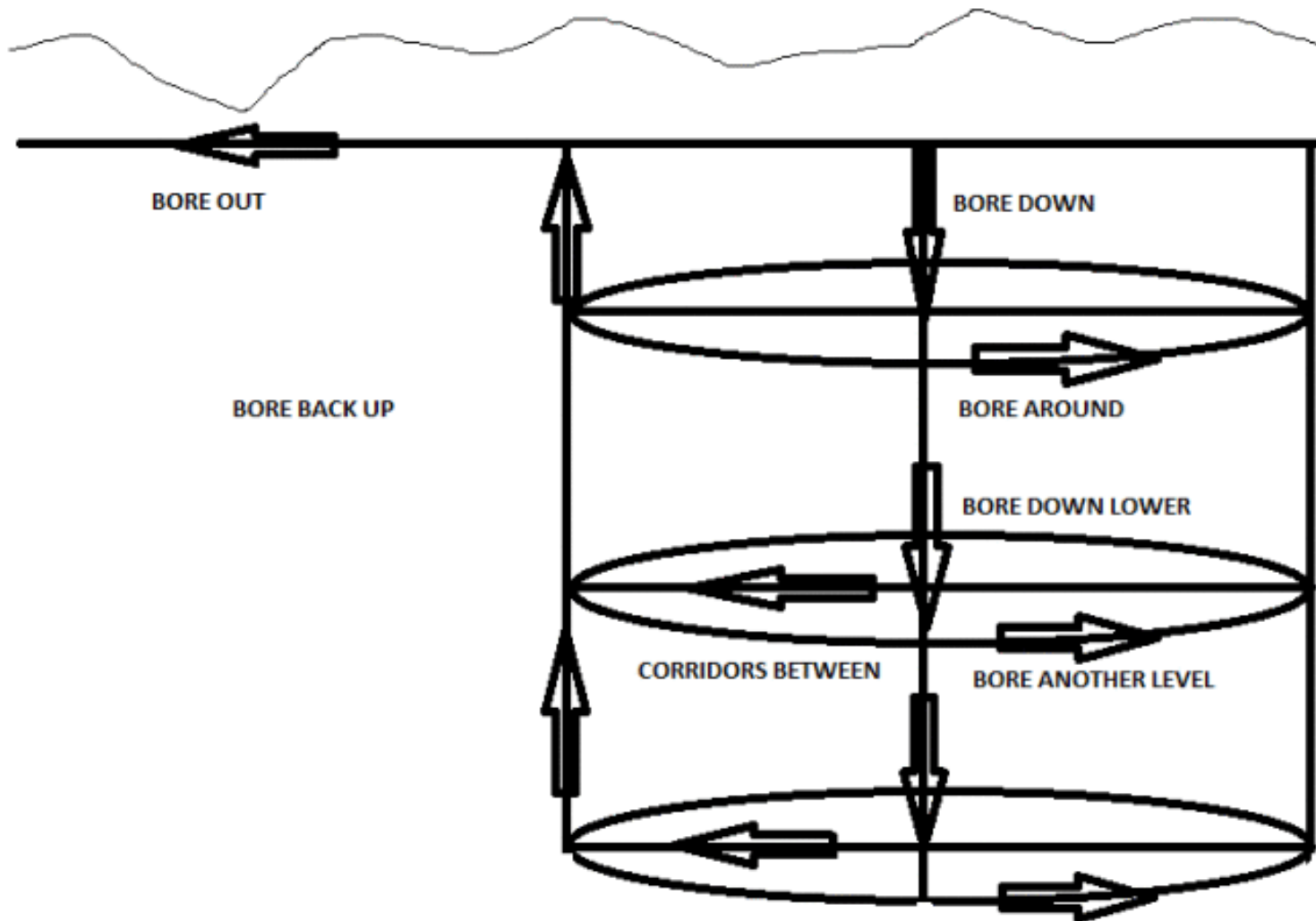

Perfect for a vacuum or semi pressurized tunnel the HyperLoop system needs. Time will tell if these **patents** get pulled into use for a **scaled up project.**

[Method and apparatus for tunneling by melting US 3693731 A](#)

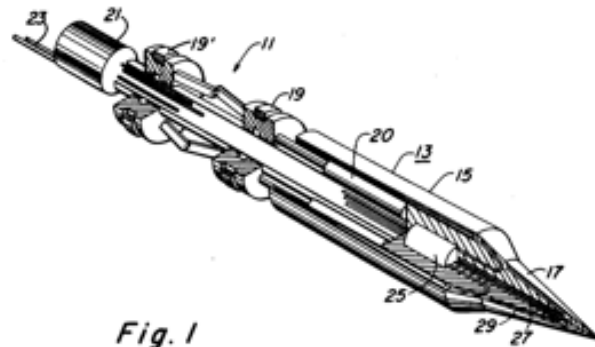

Fig. 1

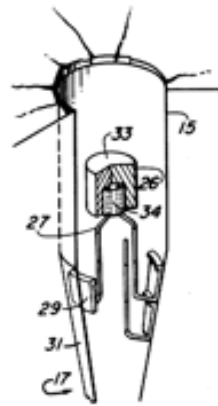

Fig. 2

INVENTOR,
Dale E. Armstrong, Berthus B. McInteer,
Robert L. Mills, Robert M. Potter,
Eugene S. Robinson, John C. Rowley,
Morton C. Smith
BY *Richard A. Goodson*
attorney

Apparatus and method for large tunnel excavation in hard rock
US 3885832 A

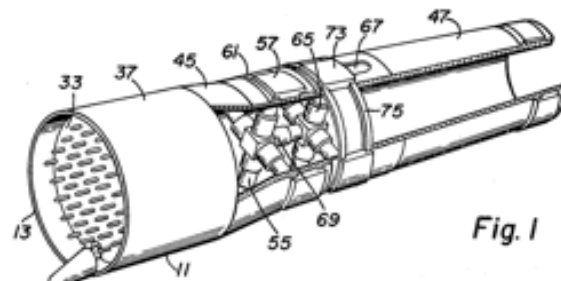

Fig. 1

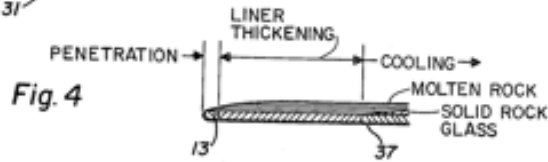

Fig. 4

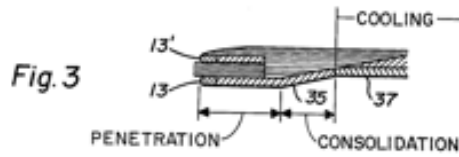

Fig. 3

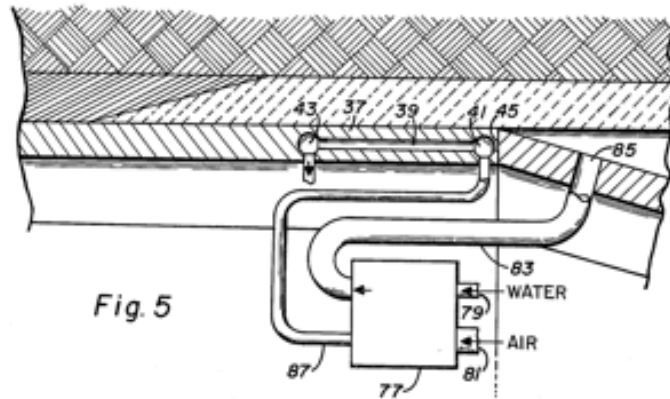
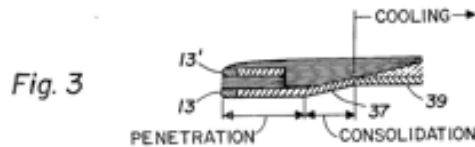
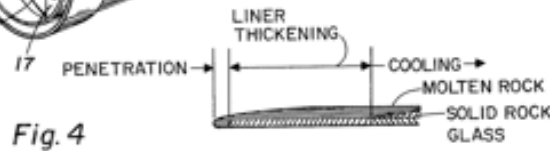
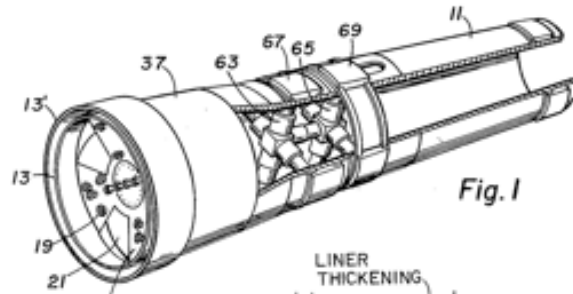
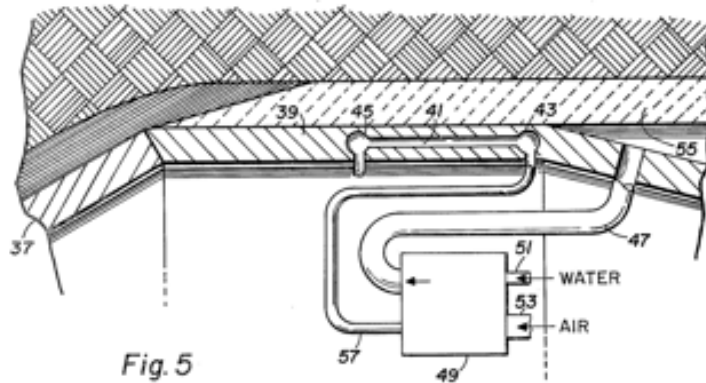

Fig. 5

Apparatus and method for large tunnel excavation in soft and incompetent rock or ground US 3881777 A



Salter said many tunnels are dug nowadays almost as they would have been in the dark ages. Drilling holes in tunnel faces, and using machines with rotary bits are methods of tunneling that can be improved, according to him. He said the tunnel could be worked on from a great many "faces," for instance. Salter suggested, too, that **electronic beams** or even water be used to drill holes for blasting. **The high-powered electrons would drill blasting holes almost instantaneously.** LA Times June 11 1972



Indeed the **HyperLoop** concept is **almost identical** to **Salter's** work in form and function with a few **minor tweaks**. The **SpaceX** design paper gives credit to **Rand** and **Salter's** work. Even the justifications for such a project are **mirrored almost exactly**.

*Is there truly a new mode of transport – a fifth mode after planes, trains, cars and boats – that meets those criteria and is practical to implement? **Many ideas for a system with most of those properties have been proposed** and should be acknowledged, reaching as far back as Robert Goddard's to proposals in recent decades by the **Rand Corporation** and **ET3**. **HyperLoop** Design Concept p 2*

What **form** this project will take in it's final version is **unclear**. If it is built to full scale at all. What is **clear** is that this line of **research and development** is based off an idea **long ridiculed in the main stream**. Is this another **advanced technology** to be mainlined to the public now that it's time?

Sources:

http://www.spacex.com/sites/spacex/files/hyperloop_alpha-20130812.pdf

<http://www.usatoday.com/story/money/2017/01/25/elon-musk-the-boring-company-tunnels/97030778/>

<https://twitter.com/>

<http://www.rand.org/pubs/papers/P4874.html>

<http://www.rand.org/pubs/papers/P6092.html>

<https://www.google.com/patents/>

<https://www.intellihub.com/l-a-to-n-y-in-half-an-hour-10000-plus-m-p-h-tunnel-train-developed/>